



Water sustains life,
ours sustains a lifestyle.



Water Dispensers and Filtration Solutions

Product Guide 2023 VS01



Contents:

1. Water Dispensers
2. Water Filters
3. Scheduled Services
4. Emerging Trends
5. Equipment Selection Form.

Water Cooling Solutions

Freestanding Water Coolers
Counter Top Water Coolers

Free Standing – Pure Water Coolers

PWC5280

PWC5280-W (White)



PWC5280 - Commercial 2-Temp Point-of-Use dispensers

- Two temperatures – **Hot** and Cold (PWC 5281 is Cool/Cold)
- Tomlinson dispensing valves (made in USA)
- Uses high-quality Panasonic or LG compressor
- G.A. Murdoch tubing (USA)
- Food-Grade 304 stainless steel hot and cold tanks
- Dual mechanical floats insure shut-off when full
- No electronics or solenoid to service
- Can be converted from bottle-less to bottled in the field
- No-dribble Easy-Lever faucets with hot safety lever
- 8.5" fill area allows larger cups, mugs or reusable bottles
- Removable drip-tray is dishwasher safe
- One-piece blow-molded high-density polyethylene cabinet that is scratch, dent and UV resistant for long life
- Available in Back or White
- Meets Energy Star 2.0 requirements

Specifications

Weight: 33 lb. .
Dimension: 12.5" W x 13" D x 37" H
Cold tank volume 1 gal
Hot tank volume .32 gal
Cooling Rate: 1.5 gal/hr 37-50 °F

Heating Rate: 1.3 gal/hr 180 °F
Voltage: 115 VAC
Power Required: 600w max
Meets Energy Star Requirements
ADA compliant



Vertex Water Products CF-5280.1

Free Standing – Executive Water Coolers



PWC 1800 – The Latest 2-temp Design with Upscale Look

Newest bottle-less water cooler with integrated cup holder and no-touch, single dispensing faucet provides great tasting hot or cold water at a touch of a button. The built-in filter system provides unlimited supply of fresh great tasting water when you need it eliminating the cost and hassle of 5-gallon bottles.

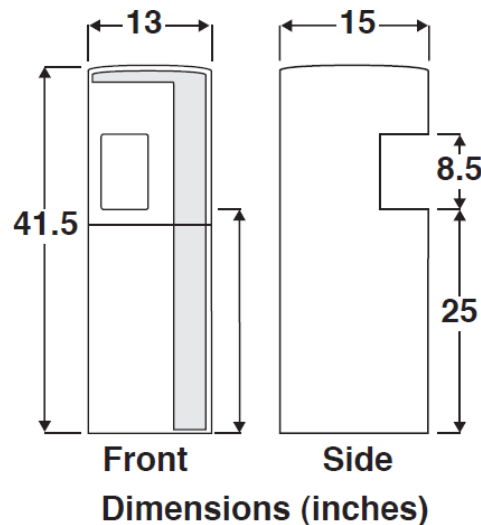

Features - PWC 1800

Two temperature system

Cold: 37-50° F,

Adjustable Hot: 180° F,

LED indicator for Hot and Cold water on the front panel,

Newly designed fill opening allows larger cups, mugs or reusable bottles

Hygienic dispensing touch pad control with no-touch dispensing faucet

Individual on/off control switches for cold and hot water on rear panel

Completely sealed stainless steel cold reservoir and hot tank

Built-in filtration system is easily accessed for replacement

Works with Reverse Osmosis filtration systems or Bev-Guard filtration

Specifications

Weight: 58 lb.

Dimension: 13"W x 15"D x 42.5"H

Cold tank volume 1 gal

Hot tank volume .5 gal

Cooling Rate: 1.5 gal/hr 37-50 °F

Heating Rate: 1.3 gal/hr 180 °F

Voltage: 115 VAC

Power Required: 600w max

Meets Energy Star Requirements
ADA compliant

Filter System



Automatic tank full control

Fully assembled

- connection hardware included



Member
**WATER
QUALITY
ASSOCIATION**



Vertex Water Products CF-5280.1

Free Standing – Executive Water Coolers



PWC 9100 – The Latest 2-temp Design with Upscale Look

New closed system keeps environmental contaminants out, so there is no need for costly in-tank sanitization. Water is chilled on demand when it passes through the cooling chamber to the faucet

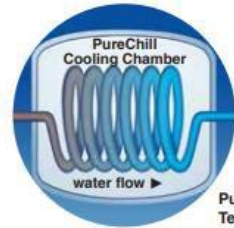

PureChill Cooling Technology



Integrated Filter Monitor



ProTekk Auto-Safety Shut-off valve

Features - PWC 9100

- No need for expensive UV and Ozone in tank sanitizers
- Integrated Filter Monitor ensures freshly filtered water
- ProTekk™ Auto Safety-Shut-Off Valve provides peace of mind
- Two temperature system
 - Cold: 37-50° F, Adjustable
 - Hot: 180° F, Autocontrol
- LED indicator for Hot and Cold water on the front panel
- Tall fill opening allows larger cups, mugs or reusable bottles
- Hygienic control touch pad with no-touch dispensing faucet
- Easy to clean control panel
- Individual on/off control switches for cold and hot water on rear panel
- Works with Reverse Osmosis filtration systems or Bev-Guard filtration

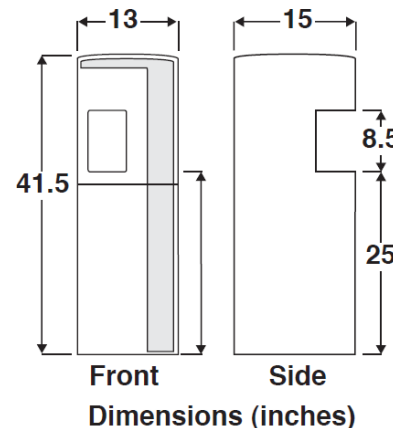

Specifications

- Shipping Weight: 50 lb.
- Dimension: 13"W x 15"D x 41.5"H
- Hot tank volume .5 gal
- Cooling Rate: 2.1 gal/hr 37-50°F
- Heating Rate: 1.3 gal/hr 180 °F
- Voltage: 115 VAC
- Power Required: 600w max



Member
WATER QUALITY ASSOCIATION



Vertex Water Products CF-5280.1

Counter Top - Avalanche



13.0"(W) X 14.5"(D) X 16.5"(H)

Avalanche (POU Water Cooler)

Hot Water options is and additional \$5/month

The Avalanche POU system features double float design and a quick connection inlet to enable easy hook-up to filtration equipment or the water supply. Still boasting its excellent chilling capacity and robust build, this counter top POU is top-of-the-line.

Secondary float acts as a safety precaution by shutting off water supply. Manual reset switch located at top of system for easy access.

Compressor operated for efficient water temperature recovery

* Green indicates normal function

* Red indicates the secondary float has been activated 5 micron air filter

¼ " inlet tube for connection to water supply

Touch Guard® handle is standard on the Hot faucet.

Durable polyethylene cabinet comes with UV protection to prevent fading.

Removable drip tray.

FDA approved self-closing Tomlinson faucets

http://www.crystalcoolers.com/north%20america/english/pou_avalanche.aspx

Avalanche: Cold only



Avalanche faucet



LED display



Carrying handle

Counter Top - Vertex PureChill PWC450



The newest VERTEX Pure Water Coolers uses PureChill™ Technology to eliminate the need for an open reservoir for cold water storage. This hot and cold bottle-less water cooler closed system keeps environmental contaminants out so there is no need for costly in-tank sanitization. The water is safely dispensed directly to your cup.

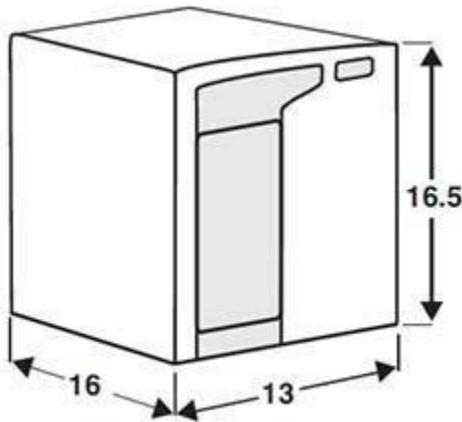

Dimensions (inches)

PureChill™ Technology

No need for expensive UV and Ozone in tank sanitizers Integrated Filter Monitor ensures freshly filtered water

ProTekk™ Auto Safety-Shut-Off Valve provides peace of mind

Two temperature system

Cold: 37-50° F, Adjustable - Hot: 180° F Autocontrol

LED indicator for Hot and Cold water on the front panel

Larger fill opening allows larger cups or reusable bottles
Hygienic dispensing touch pad control with no-touch dispensing faucet

Easy to clean control panel

Individual on/off control switches for cold and hot water on rear panel

Multi-Function Drink Stations

Water Cooling and Filtration units featuring;

*Sparkling Water

ION – 904 Water Station

<https://vimeo.com/131686986>

- 1 InstaChill™** 
Every glass is freshly filtered and instantly chilled in a Sealed Water Pathway, where air never contacts the water supply. Unlike other coolers, ION's proprietary design has no reservoir to clean or sanitize.
- 2 Cooling Capacity**
Dispense a 7 ounce glass of water every 30 seconds, for an hour... and ION makes sure it's 42°F or colder. No other cooler even comes close.
- 3 RapidHot™** 
Tea, cocoa, and even instant soups are delicious with piping hot, freshly filtered water. Up to 2 gallons per hour, convenient and ready whenever you are.
- 4 Sparkling Water Option** 
Indulge your healthy lifestyle with the healthy alternative to soft drinks. Perfect with juice, a twist of lemon or lime, or try SPLASH™ flavorings from Natural Choice.
- 5 Pure Alert Filter Monitor**
Now you know when to change your filters. Indicator lights switch from green to red when filter change is required. Filters should be replaced every 6-12 months depending on local water supply.
- 6 Save Energy**
Why run an appliance when the building is empty? ION's SleepMode™ reduces energy consumption on evenings and weekends.



- 7 Compact Size**
ION fits anywhere, from your kitchen counter to a university cafeteria.
 - 8 9" Dispensing Height**
Easily fill cups, carafes, coffee pitchers, and water bottles.
 - 9 Hygienic Design**
From the Sealed Water Pathway, ION dispenses your freshly filtered water from an easily replaceable faucet.
 - 10 Childlock**
Requires hidden button to dispense hot water (user settable).
 - 11 Removable Drip Tray**
Easy to clean and dishwasher safe. Also available in larger capacity, and with drain option.
 - 12 Filter Changes in Seconds**
A simple twist to remove the CarbonPlus™ Filter, without any tools... even without turning off the water supply. CarbonPlus filter comes standard with all appliances, rated for 1500 gallons, reducing contaminants down to 0.5 micron.
- ION® Microprocessor Control**
Proprietary software and precision sensors deliver exact temperature control and ensure high performance under extreme conditions.

Beverage Grade CO2 is sold separately and equates to about 1 cent per ounce when using the Soda Pro easy change cylinders, or .3 cents per ounce when using the 10lb cylinders. Co2 cylinders are replaced as needed. Only SodaPro and Approved ION Bulk Cylinders are licensed for use in the ION TS Water Systems.

ION – TS Water Station



1. InstaChill™

Every glass is freshly filtered and instantly chilled in a Sealed Water Pathway where air never contacts the water supply.

2. Cooling Capacity

Dispense an 8-ounce glass of water every 30 seconds, for an hour ... and ION makes sure it's 42°F or colder. No other cooler even comes close.

3. Rapidhot™

Tea, cocoa, and even instant soups are delicious with piping hot, freshly filtered water. Up to two gallons per hour, convenient and ready whenever you are.

4. Sparkling Water

Indulge your healthy lifestyle with the healthy alternative to soft drinks. Refreshing with juice, or a twist of lemon or lime.

5. Quick Filter Changes

A simple twist to remove the filter, without any tools ... even without turning off the water supply.

6. Energy Savings Mode

Why run an appliance when no one is using it? Schedule ION's Sleepmode™ to reduce energy consumption anytime, anywhere.

7. Touchscreen Technology

Easy to use Touchscreen allows users to customize settings, and provides maintenance reminders.

8. SodaPro Regulator

Optional feature for easy to change CO2 supply. Provides up to 250 8-ounce glasses.

ION Microprocessor Control

Proprietary software and precision sensors deliver exact temperature control and ensure high performance under extreme conditions.



Beverage Grade CO2 is sold separately and equates to about 1 cent per ounce when using the Soda Pro easy change cylinders, or .3 cents per ounce when using the 10lb cylinders. Co2 cylinders are replaced as needed. Only SodaPro and Approved ION Bulk Cylinders are licensed for use in the ION TS Water Systems.



DOZENS OF STILL & SPARKLING FLAVORS

Choose your favorite from peach tea to coconut, and many from your favorite brands like AriZona.

Healthily hydrate: zero to low sugar, no artificial preservatives and many flavors have vitamins and minerals to keep you performing your best.

**Alpine
Start.**



**.SUPER.
NATURALS
BY
LAVIT**

EBOOST

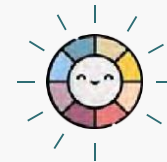

SAFETY FIRST

Automatic self sanitizing, Lavit set a new standard for beverage dispensers.

Lavit is made with antibacterial and antimicrobial materials, reducing the risks of standing water.



SPACE SAVING

Lavit's flavors come in compact, 100% recyclable aluminum EcoCaps, each takes 5X less space than packaged drinks. That means more shelf space and more flavor. It's a win-win.



The Coffee Connection
Calgary - Edmonton - Red Deer
info@thecoffeeconnection.ca



CELSIUS



This signature rich, juicy flavor of oranges comes with B and C vitamins, Green Tea Extract, and Guarana Seed Extract for extra energy!



LAVIT ORIGINALS



Need a boost? Say goodbye to gross and harsh energy drinks and hello to renewable energy! Full of vitamins and minerals to keep you going.

EBOOST ↗



Amp your focus with a delicious mix of vitamins, electrolytes, antioxidants, nootropics, and natural caffeine. With 100% daily value of D, B12 and Zinc, you will feel the difference.

Get dozens of flavors on tap. Now available from Lavit.



Hi, I'm Bevi

The smart water cooler—bringing flavors, fizz, and eco-friendly fun to your workplace.



Still or sparkling?

Bump up the bubbles or stick with the classic. Choose from still, light sparkling, or sparkling for the right amount of fizz.

We're hot and we're cold

Select the temperature you're in the mood for—cold, ambient, or hot. Try hot water to make tea, then come back for a cold glass of sparkling water.

Top it off with an enhancement

Add up to 2 enhancements, like Immunity or Caffeine, into every beverage.

What's your flavor?

Choose from over 12 natural flavors, mix up to 3 at once, and adjust flavor strength to create your custom combination.

Know what's in your beverage

Quickly see the calories, sugar, and caffeine levels in your beverage as you dispense.

See your impact

Use the "Explore" tab to see your environmental impact, bottles saved counter, flavor ingredients, and more!



Bevi – Spec's

Different flavors of Bevi

We are constantly searching for the best-tasting flavors out there. Speak to your Bevi contact if there is a flavor below that you'd like to try.

Please check www.bevi.co for the latest list.



Refill station

Our machine accepts any container. With our single-nozzle design and LED lighting, filling up is clean and easy.

Touchscreen dispense

This is where a user selects their custom drink: still, sparkling, flavored, or not.

Water/power supply

- Standard 3-prong US 120V electrical outlet, draws less than 9 amps.
- 3/8" outer diameter water line.

Specifications

Dimensions	66"h x 16"w x 21.25"d
Weight	300 lbs.
Dispensing Height	12"
Water Options	Sparkling and cold still with and without added flavor and enhancements
Cooling Capacity	Unlimited
Hot Tank Capacity	0.79 gallon/3 liters
Rated Voltages/Frequency	115v/60Hz
Power Consumption	12 amps max



CO2 Supply for Sparkling Water

Sparkling Water Accessories

Cool, crisp, sparkling water is just moments away. Easily add a refillable CO2 tank with a regulator and you're ready to experience the endless bubbly refreshment that is the fastest growing trend in cold beverages!

CO₂ Tanks

- 14.5oz Soda Pro or Soda Stream
Carbonates up to 250 – 8oz Glasses (Approx. 1 cent per ounce)
Ion Touch Series and Soda Stream Systems Only
- 10 lb. CO₂ Aluminum Cylinder
Carbonates up to 3000 – 8oz Glasses (Approx. 0.3 cents per ounce)
Ion 900 Series, Ion Touch Series, Follet and Bevi Systems

CO₂ Regulator

Includes Wrench and Pressure Gauge.

CO₂ Cylinder Deposits

Soda Stream \$19.00

10lb Cylinder \$100.00

Deposits are charged upon installation



Under Counter Drink Stations

Water Cooling and Filtration units that are out of sight and water is dispensed at the sink via a separate faucet.

Under counter installations

Each under counter chiller is installed with a standard faucet.
Designer faucets are available.
Designer faucets are available.



Standard Feature Faucets \$75.00 each



Tomlinson Designer Faucets \$80-\$180 each



Tomlinson Contemporary Faucets \$80-\$180 each



Under Counter – Pinnacle

Pinnacle		SPECIFICATIONS
Power rating		Single phase
		(220-240V 50Hz)
		(100-115V 60Hz)
Standard current		1.2A
Power	Cold	75W
Consumption	Hot	-
Cold	Compressor	Single phase motor
	Refrigerant	R-134a
	Capacity	11.5 l/hr (3.0 gal/hr)
Hot	Heater	-
	Temp control	-
	Capacity	-
Product weight		13.3kg (29.3 lb)
Product boxed weight		14.6kg (32.5 lb)
Product dimensions		410(W)X300(D)X300(H)mm 16.1"(W)X11.8"(D)X11.8"(H)
Product boxed dimensions		440(W)X330(D)X340(H)mm 17.3"(W)X13.0"(D)X13.4"(H)
Loading quantity		20' Container: 637 Units
		40' Container: 1323 Units

Crystal Mountain



Under Counter – Oasis R5

Oasis R5 Under counter chillers

Delivers 5 Gallons of Chilled Water Per Hour.

This unit can be Used to Serve Multiple Drinking Fountains or installed under sink to provide a compact water chilling solution.

Waterways are Lead-Free in Materials and Construction and feature a High-Efficiency Stainless Steel Cooling Tank made of Heavy-Gauge Steel

Refrigerant R-134a

Prior to roughing-in, consult local, state and federal codes for proper mounting height

Exterior is comprised of Galvanized Steel



Oasis International Product
Certified by NSF to
NSF/ANSI Standard 61.0

Model	50° F Drinking Water 90° F Ambient Air Temp*			Hot'N Cold™ Model**	115 Volts, 60 HZ			Glass Filler Acc. Option	Cabinet Color Finish	Net Wt. Approx.
	Rated Capacity GPH	Base Rate GPH	Pre-Cooler		Compr. HP	Full Load Amps	Rated Watts			
R5**	5.0	5.0	n/a	No	1/5	3.6	4.5	n/a	n/a	50 Lbs.

Water Filtration Solutions

BevGuard – Water you can trust

Delivers premium quality water for commercial appliances for consistently great tasting water, coffee and water based beverages.

- This BevGuard® brand filter contains a 0.5 micron compressed carbon block and polyphosphate scale inhibitor. The carbon block provides tremendous capacity to reduce impurities and sediment that may be present in your drinking water. The carbon block has millions of active sites on its surface and within the structure which can absorb impurities like a sponge, and can attract and hold other types of impurities to its surface like a magnet. Additionally, this filters can catalytically breakdown other impurities very similar to the way a catalytic converter works in your automobile.
- The scale inhibitor reduces the accumulation of minerals that lead to hard water spots from lime scale build up on equipment. These processes ensure that you are getting the cleanest and best tasting water possible.
- This patented BevGuard® filters requires NO ACTIVATION, is economical and will provide you with months of protection in any beverage or food equipment application. NSF Certified under NSF/ANSI Standards 42 and 53

BevGaurd 1200s \$19.95/Month

Micron Rating:	0.5 micron
Dimensions:	6½" x 3¾" (16.51 cm x 8.1 cm)
Min Operating Pressure:	25 psi (1.7 bar)
Max Operating Pressure:	125 psi - (8.6 bar)
Operating Temperature:	35-100°F (1.7°C - 38°C)
Flow Rate:	1.67 gpm (6.32 lpm)
Life:	3,500 gal (13,248 liters)



BevGaurd 3200s \$24.95/Month

Micron Rating:	0.5 micron
Dimensions:	16½" x 3¾" (41.90 cm x 8.1 cm)
Min Operating Pressure:	25 psi (1.7 bar)
Max Operating Pressure:	125 psi - (8.6 bar)
Operating Temperature:	35-100°F (1.7°C - 38°C)
Flow Rate:	2.1 gpm (7.95 lpm)
Life:	29,000 gallons (109,500 liters)



Gold Seal Reverse Osmosis - \$29.95/month

The Water Quality Association (WQA) Gold Seal represents the most credible and independent testing and validation entity in the water industry. The WQA's Gold Seal represents quality assurance through comprehensive testing and continuous research and evaluation of water treatment technologies.



The PuROTwist 4000 REVERSE OSMOSIS

semi-permeable membrane rinses contaminants to the drain. High quality, filtered drinking water is produced and conveniently stored in a sealed tank. The PuROTwist 4000 lead-free faucet easily delivers an abundant supply of clear, clean, and fresh drinking water to you and your colleagues.

Stage 1. *5 Micron Sediment Filter* : Removes dirt, sediments, sand, and other physical particles.

Stage 2. *Pre Carbon Filter* : Provides protection to the RO membrane from free chlorine and sediment.

Stage 3 *Reverse Osmosis Membrane* : Membrane reduces a high percentage of dissolved inorganics.

Stage 4 *Post Carbon Filter* : A final polishing process that enhances and clarifies your drinking water.

Our Services

Water Line Management

Expanding operator beverage menus mean more equipment than ever is being used in office and foodservice operations today. New equipment and an increasing number of beverage lines creates challenges for facilities teams in that both also mean more water lines to manage, and additional time required to identifying and trace those lines during service.

In offices Lunch rooms and Corporate break areas these days it is not uncommon to find:

- New beverage lines tangled with old lines.

- Poor or no identification of lines.

- No shut-off valves on lines.

- Hard-plumbed lines with little or no flexibility.

This can lead to:

- Time needlessly spent trying to identify lines and trace them back to the equipment.

- More time spent on a project than required or desired, leading to increased cost if it can't be billed back to the operator.

The Coffee Connection makes water line management easier for you with our John Guest quick connect plumbing fittings and ID tags.

We remove all previous vendors tubing and this cleans up unsightly mess of tangled water lines, organizing both under counter, in ceiling and exposed tubing within your location for improved appearance and maintenance efficiency. Offers quick line shut-off in case of unexpected equipment or line leaks. Reduces mistakes and spend less time spent identifying and tracing lines, plus easily shut lines off for servicing. Efficient water line serviceability reduces total equipment downtime during servicing. Easily modify system to meet changing plumbing requirements. Flexible and expansion-capable; easily add new beverage equipment in the future using your existing system. Minimal footprint and a variety of configurations available to meet your specific needs

Water Filter Management

How often should I my cartridges be changed?

In order for our filters to perform as represented and to provide the best quality water possible, it is essential that filters be replaced periodically. We recommend replacing your filter cartridge when capacity is reached or at least once every two years. The frequency of filter changes depends upon your water quality and your water usage. For example, if there is a lot of sediment and/or particles in your water, then you will have to change your filters more frequently than someone does with little to no sediment. Be sure to replace your filters whenever you notice a decline in the performance, whether it is a drop in flow rate and/or pressure or an unusual taste in the water.

The Coffee Connection has a offers scheduled services and will monitor your filter in multiples of 6 months based on the sizing of your account. If your employee bases has grown tremendously contact us so that we can resize your usage to ensure appropriate replacement schedules.

Why does my cartridges seem to slow the flow of water each month?

Because our cartridges are designed to remove contaminants and particles from the water, the cartridges will eventually plug as particles and contaminants are being captured. Therefore, plugging indicates that the cartridges are working efficiently an are removing containments.

Why does the service technician flushed a bunch of water down the drain when installing my filter?

All carbon-based filters need to be flushed to remove any excess carbon fines that are inside the cartridges. New cartridges are filled with air; therefore, flushing also removes the air from inside the cartridges and replaces it with water. The flushing process will allow any carbon-based cartridge to function at optimum levels without affecting any equipment that may be attached.

Sizing Chart for Water Filters replacement

Number of Staff using the water cooler	Liters Consumed daily. Based on drinking *750ml	Volume in liters consumed each year. *250 workdays	Suggested BevGuard Water Filter	Required Replacement schedule	Preventative Replacement and Service Plan
5	3.750	938	BevGuard 1200s	13 years	Annually
10	7.500	1875	BevGuard 1200s	6 years	Annually
15	11.250	2813	BevGuard 1200s	4 years	Annually
20	15.000	3750	BevGuard 1200s	3 years	Annually
25	18.750	4688	BevGuard 1200s	2 years	Annually
30	22.500	5625	BevGuard 1200s	2 years	Annually
35	26.250	6563	BevGuard 1200s	Annually	Annually
40	30.000	7500	BevGuard 1200s	Annually	Annually
45	33.750	8438	BevGuard 1200s	Annually	Annually
50	37.500	9375	BevGuard 1200s	Annually	Annually
55	41.250	10313	BevGuard 1200s	Annually	Annually
60	45.000	11250	BevGuard 1200s	Annually	Annually
65	48.750	12188	BevGuard 1200s	Annually	Annually
75	56.250	14063	BevGuard 3200s	7 Years	Annually
80	60.000	15000	BevGuard 3200s	7 Years	Annually
85	63.750	15938	BevGuard 3200s	6 Years	Annually
90	67.500	16875	BevGuard 3200s	6 Years	Annually
95	71.250	17813	BevGuard 3200s	6 Years	Annually
100	75.000	18750	BevGuard 3200s	5 Years	Annually

*Daily consumptions are based on 3 - 250ml servings per employee.

*Volume in liters consumed each year are based on 50, five day workweeks per employee

Equipment Selection Form

Equipment Selection Form.

Please detail below your water cooler and filtration selections.

Customer Name:

Address:

Contact Name:

Phone #:

Designation	Manufacturer	Model	Monthly Rental	Quantity	Accessories
Under Counter	Crystal Mountain	Pinnacle	\$ 10.00		Select water filter
Under Counter	Oasis	R5	\$ 15.00		Select water filter
Free Standing	Vertex	BW5281 Cool and Cold	\$ 15.00		Select water filter
Free Standing	Vertex	BW5280 Hot and Cold	\$ 15.00		Select water filter
Free Standing EXEC	Vertex	PWC-1800	\$ 25.00		Select water filter
Free Standing EXEC	Vertex	PWC-9100	\$ 50.00		Select water filter
Counter Top	Crystal Mountain	Avalanche	\$ 10.00		Select water filter
Counter Top EXEC	Vertex	PWC 450/900	\$ 30.00		Select water filter
Multi Function	Lavit	Cold Still / Cold Sparkling	\$ 65.00		Select water filter
Volume Rated					
Water filtration	BevGuard / Omnipure	1200+ Gallons	\$ 19.95		Select dispenser
Water filtration	BevGuard / Omnipure	3200+ Gallons	\$ 24.95		Select dispenser
Water filtration R.O.	PuRO Twist	PuROtwist 4000	\$ 29.95		Select dispenser
Water Softening	ELF - Omnipure	700+ grains	\$ 29.95		Select dispenser
Multi Function	ION TS 400	Hot/Cold/Ambient/Sparkling	\$ 105.00		Water Filter included
Multi Function	BEVI – G2	Full Sized Stand Up	\$ 599.99		Water Filter included
Multi Function	BEVI Flavor Bibs	Flavours - 400 Servings/box	\$ 199.99		Water Filter included
CO2 Supply	SodaPro 14.5oz Cylinder	Beverage Co2 – 300 Cups	\$ 25.00 / Exchange		Deposit \$20.00
CO2 Supply	Lavit 24oz Cylinder	Beverage Co2 – 300 Cups	\$ 40.00 / Exchange		Deposit \$35.00
CO2 Bulk Supply	10lb Cylinder	Beverage Co2 – 3000 Cups	\$ 175.00 / Exchange		No Charge
Installation	TCC	New / Move / Additional	Included in rental fee		No charge
Cleaning / Maintenance	TCC	Annually	Included in rental fee		No Charge
Cartridge Replacement	TCC	Annually	Included in rental fee		No Charge

--Select Filter-- -----Select your dispenser-----