

# Ultra-2 HP Manual Fill

32.0" x 24.5" x 16.0"  
(81.3cm x 62.2cm x 40.6cm)



- Full 2-year parts and 1-year labor warranty. 5-year parts and 1-year labor warranty on compressor and 3-year parts and labor warranty on electronics. See the product manual for additional details.
- Large 3gal (11.4L) hopper for optimum cooling and serving capacity
- Refrigeration system internally monitored to ensure long lasting performance
- Reversing auger design quickens freeze time and reduces air mixing
- Very simple to program and run with touchpad display, which also guides cleaning and preventive maintenance

 Servers and airpots sold separately

Agency:



## Specifications

**Product #:** 34000.6080

**Finish:** Black

**Hoppers:** Two

**Handle:** Extended Handle

**Water Access:** Not Plumbed

## Additional Features

## Electrical & Capacity

| Volts | Amps | Watts | Cord Attached | Plug Type  | 8oz cups/hr<br>236ml cups/hr | Input H <sub>2</sub> O Temp. | Phase | # Wires plus Ground | Hertz |
|-------|------|-------|---------------|------------|------------------------------|------------------------------|-------|---------------------|-------|
| 120   | 12   | 1440  | Yes           | NEMA 5-15P | -                            | 60°F (15.5°C)                | 1     | 2                   | 50/60 |

## Plumbing Requirements

| PSI | kPa | Fitting Supplied | Water Flow Required (GPM) |
|-----|-----|------------------|---------------------------|
| -   | -   | -                | -                         |

## CAD Drawings

| 2D | Revit | KLC |
|----|-------|-----|
| ●  |       |     |



BUNN® reserves the right to change specifications and product design without notice. Such revisions do not entitle the buyer to corresponding changes, improvements, additions or replacements for previously purchased equipment. For most current specifications and other info visit [bunn.com](http://bunn.com).

Created on:  
10/31/2016

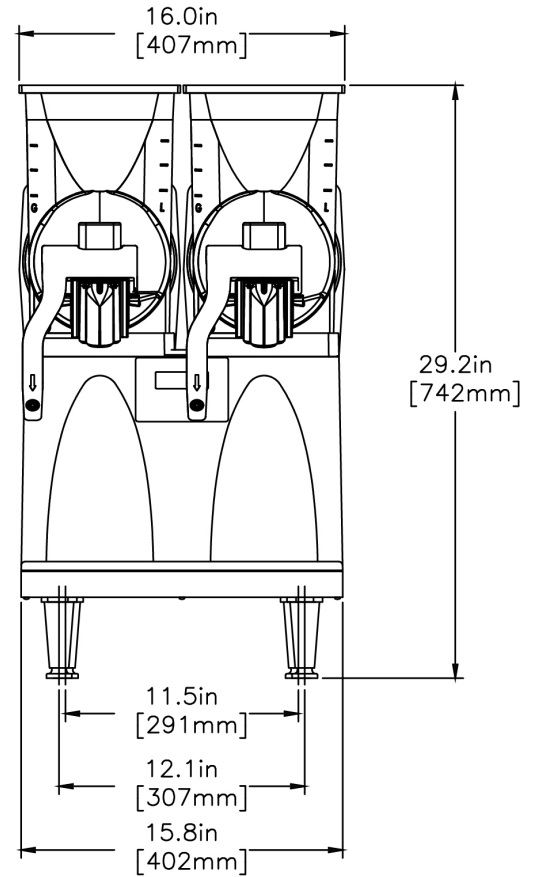
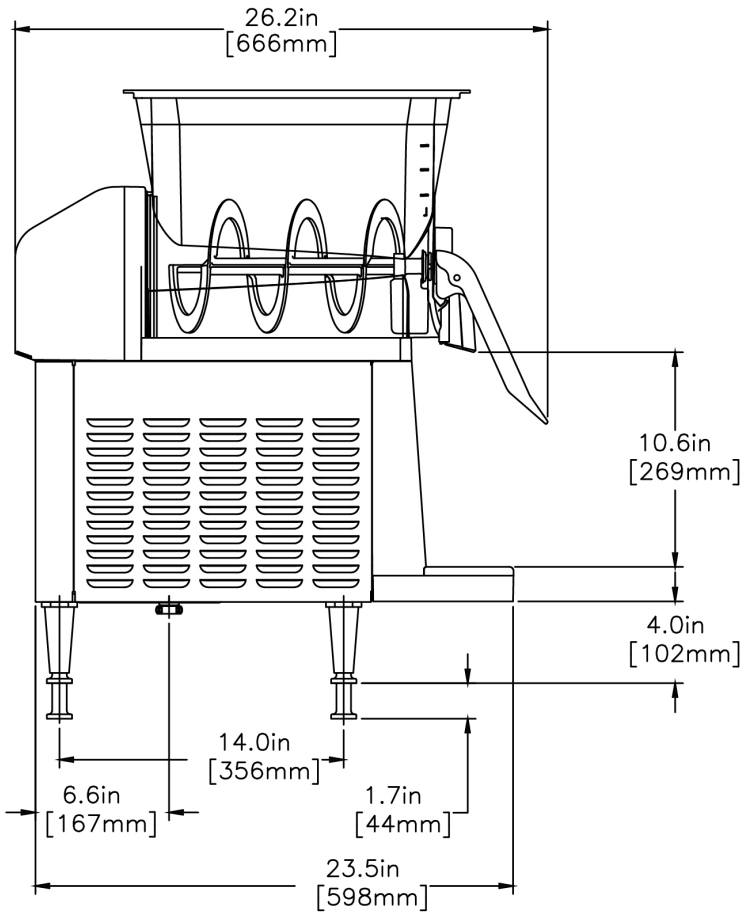
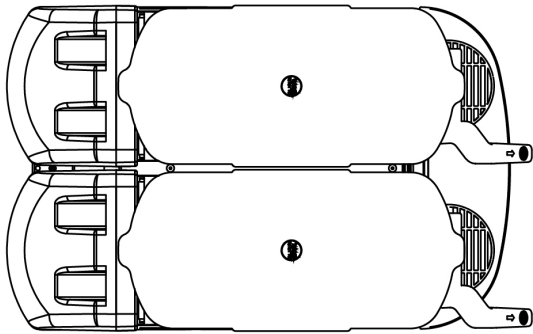

|         | Unit     |          |          | Shipping |        |       |           |        |
|---------|----------|----------|----------|----------|--------|-------|-----------|--------|
|         | Width    | Height   | Depth    | Width    | Height | Depth | Weight    | Volume |
| English | 16.0 in. | 32.0 in. | 24.5 in. | -        | -      | -     | 0.000 lbs | -      |
| Metric  | 40.6 cm  | 81.3 cm  | 62.2 cm  | -        | -      | -     | 0.000 kgs | -      |



BUNN® reserves the right to change specifications and product design without notice. Such revisions do not entitle the buyer to corresponding changes, improvements, additions or replacements for previously purchased equipment. For most current specifications and other info visit [bunn.com](http://bunn.com).

Created on:  
10/31/2016

Related Products & Accessories: Ultra-2 HP Manual Fill(34000.6080)



DRIP TRAY ASSY,  
LOWER-BLK

Product #: 28086.0001

COVER, DRIP TRAY  
ULTRA 2 BLK

Product #: 32068.0001

ULTRA LAF KIT,SEP  
WATER LINES

Product #: 37960.0000

KIT, CFV UPGRADE W/  
HPRS ULTRA-2 BLK .035

Product #: 44071.0101



BUNN® reserves the right to change specifications and product design without notice. Such revisions do not entitle the buyer to corresponding changes, improvements, additions or replacements for previously purchased equipment. For most current specifications and other info visit [bunn.com](http://bunn.com).

Created on:  
10/31/2016

# Serving & Holding Options: Ultra-2 HP Manual Fill(34000.6080)

\*Serving and Holding selections are currently unavailable. Please contact your sales representative to find out more information.\*



BUNN® reserves the right to change specifications and product design without notice. Such revisions do not entitle the buyer to corresponding changes, improvements, additions or replacements for previously purchased equipment. For most current specifications and other info visit [bunn.com](http://bunn.com).

Created on:  
10/31/2016